

PIASTRA DI BASE : ALU 059

CONTROPIASTRA E TELAIO

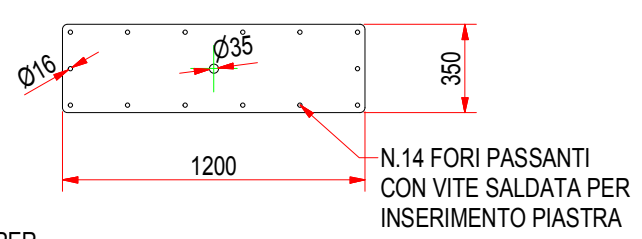

B-B

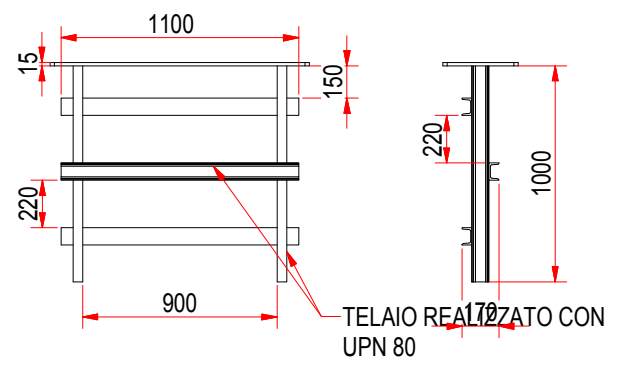
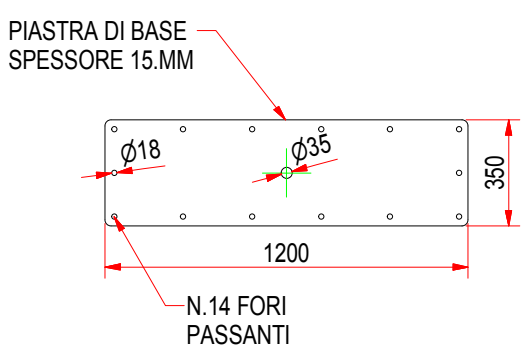
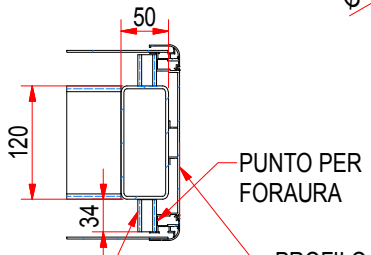

TUB 20X20 SP.3 FISSAGGIO PROFILO

C-C

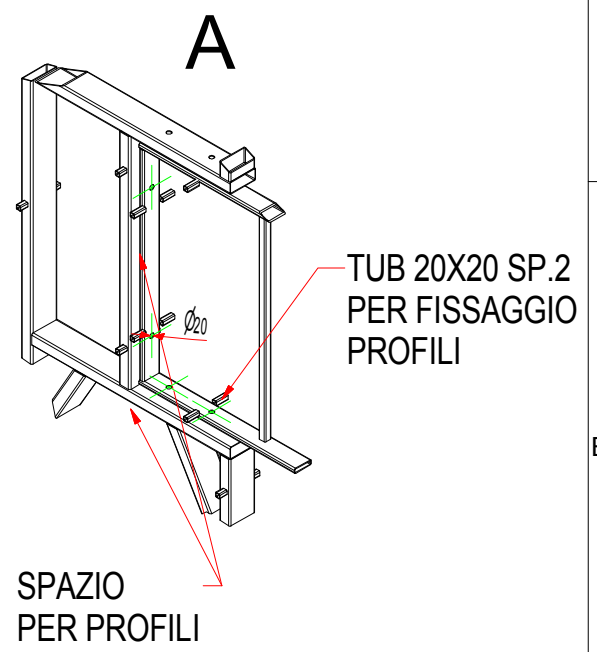
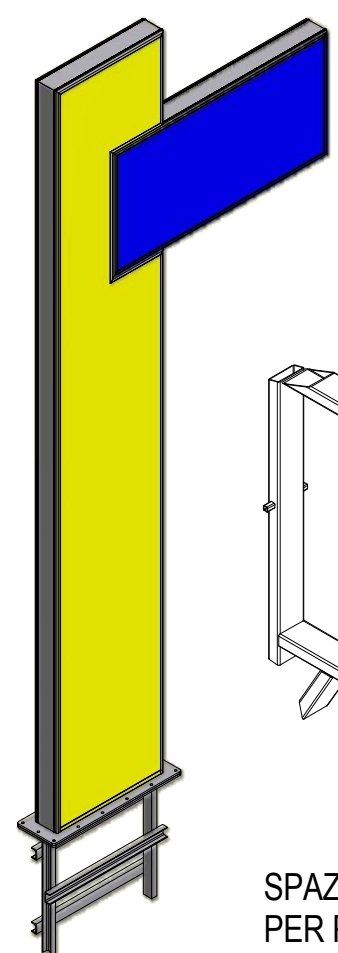
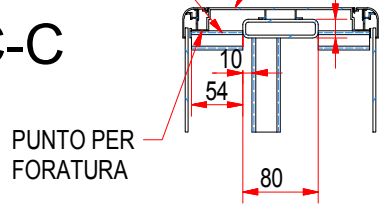

SE NON DIVERSAMENTE SPECIFICATO TUTTE LE QUOTE SONO IN mm E SI INTENDONO A PEZZO FINITO		- ALBERI..... H11 UNI EN 20286-2:1995		-TRA SUPERFICI..... 0.2 SU 100	
		- FORI..... H11 UNI EN 20286-2:1995		- Ø CONCENTRICITÀ E COASSIALITÀ..... 0.2 SU 100	
		- ALTRE QUOTE..... Js11 UNI EN 20286-2:1995		- / ERRORE DI ROTAZIONE..... 0.2 SU 100	
		- VALORI ANGOLARI..... ± 30°		- RUGOSITÀ Ra..... 3.2 µm	
		- SMUSI DI SPIGOLI..... DA 0.2 A 0.5		- CARPENTERIA SALDATA..... Js 13	
		- RACCORDI CONCAVI..... DA 0.5 A 1.0		- CARPENTERIA CHIODATA..... Js 14	
		- FILETT. QUAL. MEDIA..... UNI 5545:1965		- VALORI ANGOLARI SU CARPENTERIA..... ± 45°	
		- J. TRA SUPERFICI E RISPETTO ASSI..... 0.1 SU 100			
PROCEDIMENTO DI SALDATURA SECONDO CNR UNI 10011 2.5.1 CLASSE I SECONDO 2.5.3 PREPARAZIONE E DIMENSIONE SECONDO SPECIFICA D60918	PROG. fmarri	12/07/2010	T. TERMICO	T. SUPERFICIALE	
<p>VIA DEI CARRAI, 15 06019 UMBERTIDE (PS) TEL +39 075 9417751 FAX +39 075 9412854 E-MAIL SIGN@ALUTECHITALIA.COM</p>	GREZZO		MATERIALE		MASSA N/A
	DISEGNO N.		ART324		A3