

CONTROPIASTRA E TELAIO

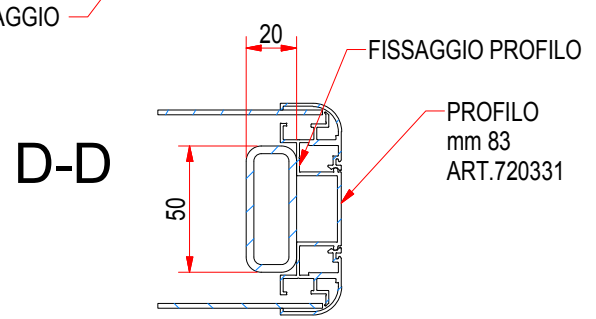
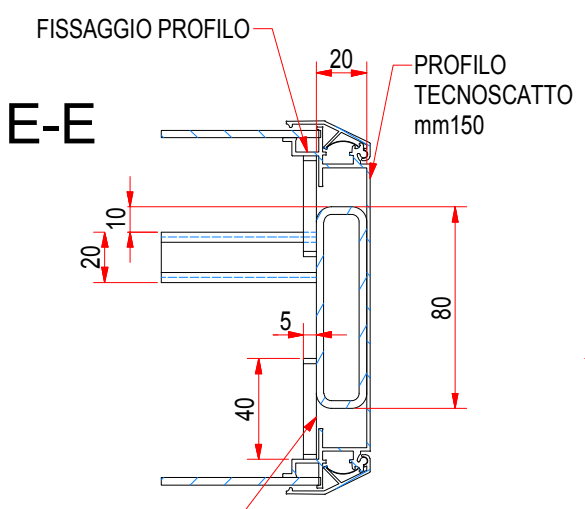
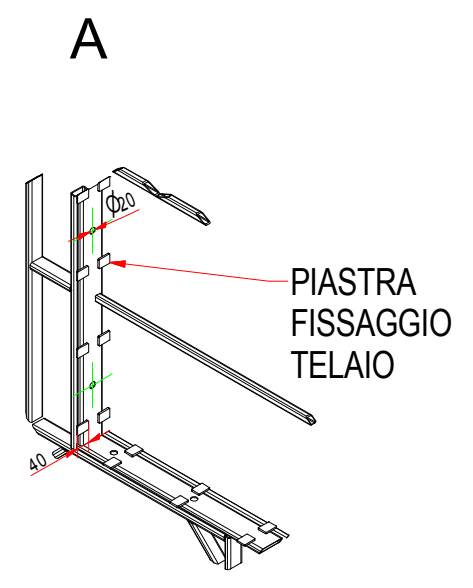
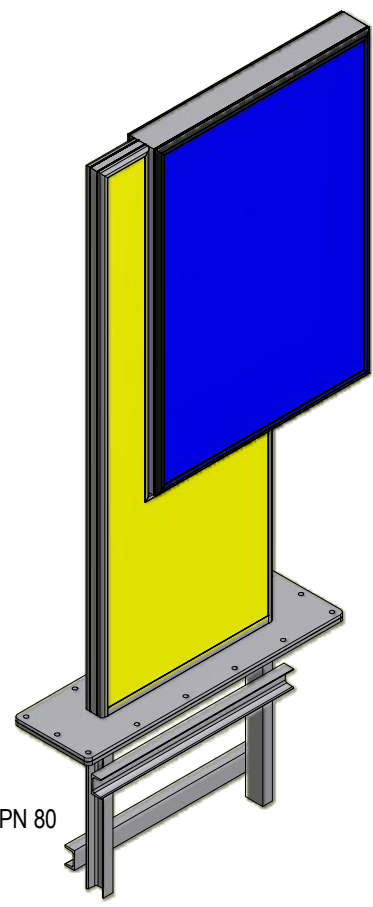
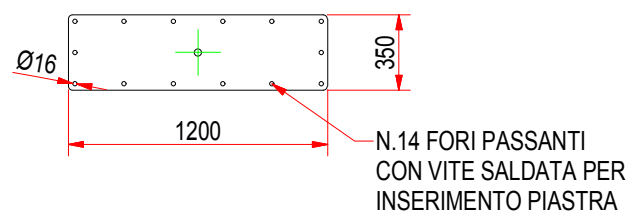
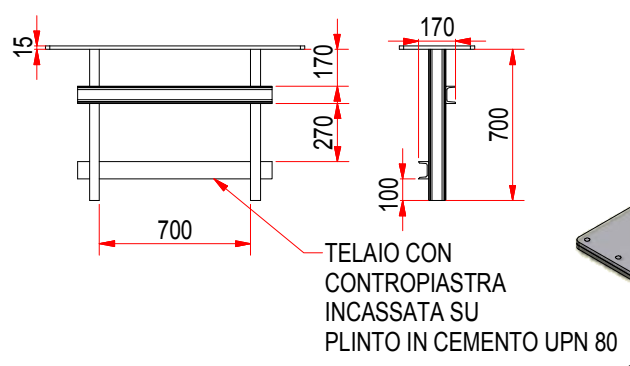

SE NON DIVERSAMENTE SPECIFICATO TUTTE LE QUOTE SONO IN mm E SI INTENDONO A PEZZO FINITO		- ALBERI..... h11 UNI EN 20286-2:1995		- TRA SUPERFICI..... 0.2 SU 100	
		- FORI..... H11 UNI EN 20286-2:1995		- CONCENTRICITÀ E COASSIALITÀ..... 0.2 SU 100	
		- ALTRE QUOTE..... js11 UNI EN 20286-2:1995		- ERRORE DI ROTAZIONE..... 0.2 SU 100	
		- VALORI ANGOLARI..... ± 30'		- RUGOSITÀ Ra..... 3.2 µm	
		- SMUSSI DI SPIGOLI..... DA 0.2 A 0.5		- CARPENTERIA SALDATA..... js 13	
		- RACCORDI CONCAVI..... DA 0.5 A 1.0		- CARPENTERIA CHIODATA..... js 14	
		- FILETT. QUAL. MEDIA..... UNI 5545:1965		- VALORI ANGOLARI SU CARPENTERIA..... ± 45'	
		- TRA SUPERFICI E RISPETTO ASSI..... 0.1 SU 100			
PROCEDIMENTO DI SALDATURA SECONDO CNR/UNI 10011 2.5.1 CLASSE I SECONDO 2.5.3 PREPARAZIONE E DIMENSIONE SECONDO SPECIFICA D6091B		PROG. <i>Ing. A. Palazzetti</i>	03/08/2010	T. TERMICO	T. SUPERFICIALE
		GREZZO		MATERIALE	MASSA N/A
VIA DEI CARRAI, 15 06019 UMBERTIDE (PS) TEL. +39 075 9417751 FAX +39 075 9412854 E-MAIL SIGN@ALUTECHITALIA.COM		DISEGNO N.		ART328	FOGLIO 1 di 1